

DO NOT SCALE FROM THIS PRINT

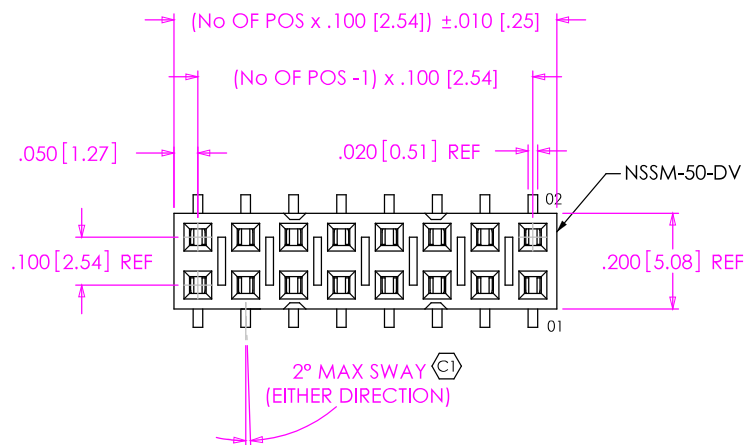

R No OF POSITIONS
 -02 THRU -40
 (PER ROW) (SEE NOTE 7)

PLATING

- S: SELECTIVE GOLD (USE C-137-01-S)
- L: LIGHT SELECTIVE GOLD (USE C-137-01-L)
- T: TIN (USE C-137-01-T)
- F: FLASH SELECTIVE GOLD (USE C-137-01-F)
- P: GOLD FLASHED PALLADIUM NICKEL (USE C-137-01-P)
- H: HEAVY GOLD (USE C-137-01-H)
- STL: SELECTIVE TIN/LEAD (USE C-137-01-STL)
- SM: SELECTIVE GOLD/MATTE TIN TAILS (USE C-137-01-S)
- LM: LIGHT SELECTIVE GOLD/MATTE TIN TAILS (USE C-137-01-L)
- TM: MATTE TIN (USE C-137-01-T)
- FM: FLASH SELECTIVE GOLD/MATTE TIN TAILS (USE C-137-01-F)

OPTION

- A: ALIGNMENT PIN (SEE FIG. 3, SHT 2) (MOLDED: USE NSSM-XX-DV-XX, 4 POS MIN)
- P: PICK & PLACE PAD (SEE NOTE 5) (USE PPP-01, SEE FIG. 4, SHT 2)
- M: METAL PICK & PLACE PAD (SEE NOTE 5) (USE MPP-02, SEE FIG. 5, SHT 2)
- K: POLYAMIDE FILM PAD (SEE NOTE 5) (POS 5 TO 40 ONLY) (USE K-500-300, SEE FIG. 6, SHT 2)
- TR: TAPE & REEL (SEE FIG 8, SHT 2-29 POSITIONS MAX)

OPTION

- BE: BOTTOM ENTRY (ONLY AVAILABLE ON -DV) (FOR -DV SEE NSSM-50-DV-XX)

POLARIZING OPTION

- XX: POSITION TO BE POLARIZED (USE PK-01) (SEE FIG 7, SHT 2)

MOUNTING OPTION

- LC: LOCKING CLIP (USE LC-05-TM) (SEE FIG. 2)

ROW SPECIFICATION

- DV: DOUBLE VERTICAL (USE NSSM-XX-DV-XX) C-137-01-XXX

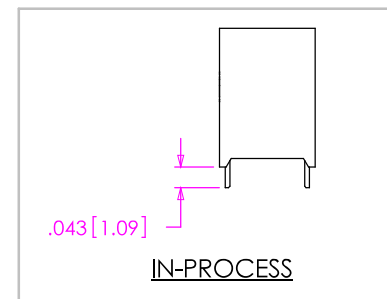
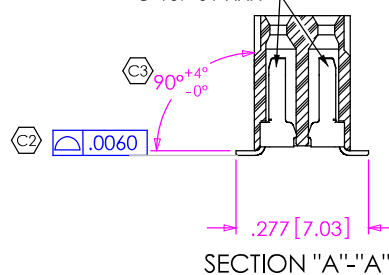
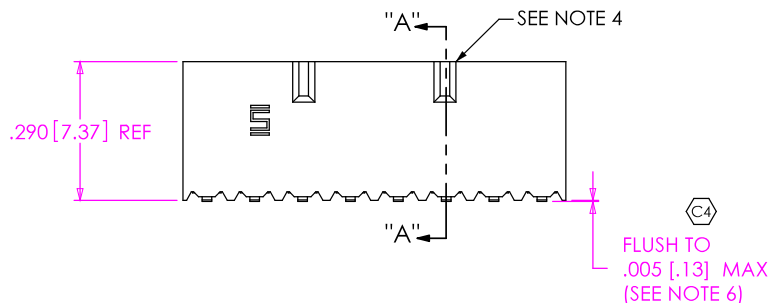

NOTES:

1. (C) REPRESENTS A CRITICAL DIMENSION.
2. PULLOUT FORCE TO BE: 1 Lb MIN.
3. MAXIMUM CUT FLASH: .010.
4. CUT PARTS MAY OR MAY NOT HAVE NOTCHES
5. -P OPTION: 4 POSITION AND UNDER TO BE -T/R
 -M OPTION: 3 POSITION AND UNDER TO BE -T/R
 -K OPTION: 3 POSITION AND UNDER TO BE -T/R
 ALL OTHER POSITIONS WITH -P, -M, -K OPTIONS ARE TO BE TUBED
6. FLUSH DIMENSION MUST BE INSPECTED ON BOTH ROWS OF ASSEMBLY.
7. -40 MAX POSITION AVAILABLE, -50 FOR STOCK ONLY

FIGURE 2

-LC: LOCKING CLIP OPTION

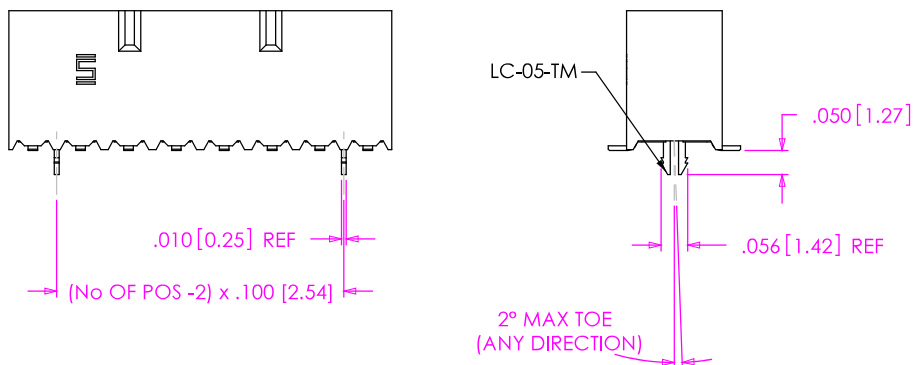

UNLESS OTHERWISE SPECIFIED, DIMENSIONS ARE IN INCHES.

TOLERANCES ARE:

- DECIMALS
- ANGLES
- .XX: ±.01 [.3]
- .XXX: ±.005 [.13]
- .XXXX: ±.0020 [.051]

PROPRIETARY NOTE

THIS DOCUMENT CONTAINS INFORMATION CONFIDENTIAL AND PROPRIETARY TO SAMTEC, INC. AND SHALL NOT BE REPRODUCED OR TRANSFERRED TO OTHER DOCUMENTS OR DISCLOSED TO OTHERS OR USED FOR ANY PURPOSE OTHER THAN THAT WHICH IT WAS OBTAINED WITHOUT THE EXPRESSED WRITTEN CONSENT OF SAMTEC, INC.

SAMTEC

520 PARK EAST BLVD, NEW ALBANY, IN 47150
 * PHONE: 812.944.6733 FAX: 812.948.5047
 e-Mail: INFO@SAMTEC.COM CODE: 55322

MATERIAL: DO NOT SCALE DRAWING SHEET SCALE: 2.5:1

BODY: VECTRA E130i
 CONTACT: PHOS BRONZE

DESCRIPTION:
 .100 C.L. DOUBLE VERTICAL SMT SOCKET STRIP

DWG. NO.
SSM-1XX-XXX-DV-XX-XX-X-XX

BY: KEVIN B 3/8/2000 SHEET 1 OF 2

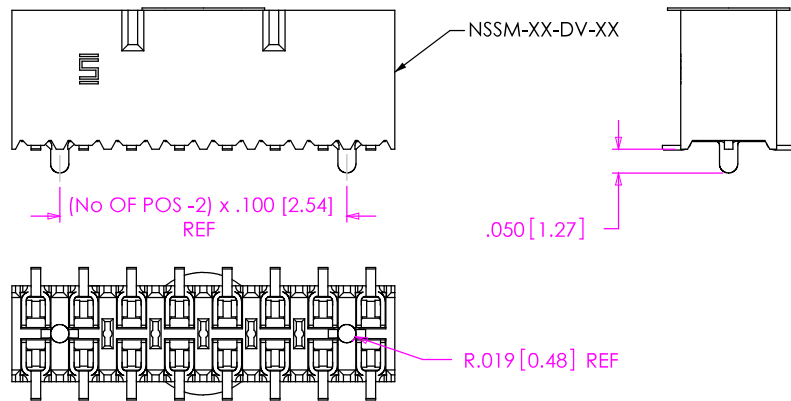

FIGURE 3
-A: ALIGNMENT PIN
MOLDED (4 POSITION MIN)

FIGURE 8
TAPE & REEL VIEW

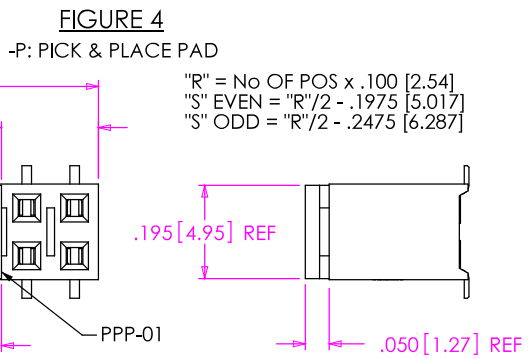
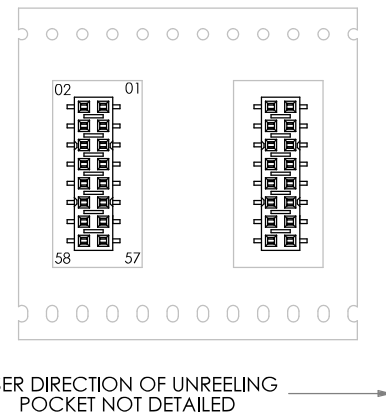

FIGURE 4
-P: PICK & PLACE PAD

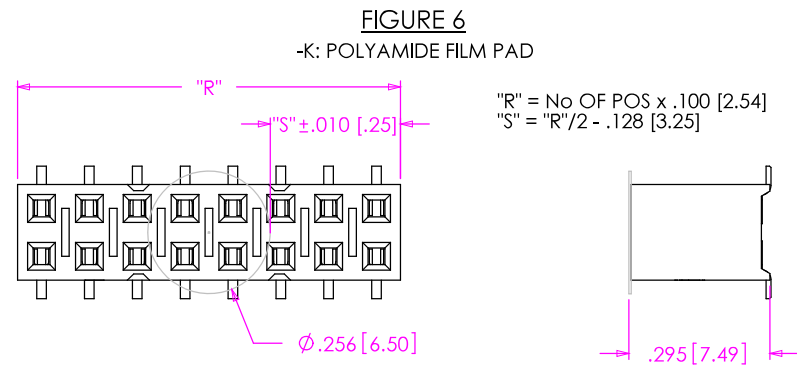

FIGURE 6
-K: POLYAMIDE FILM PAD

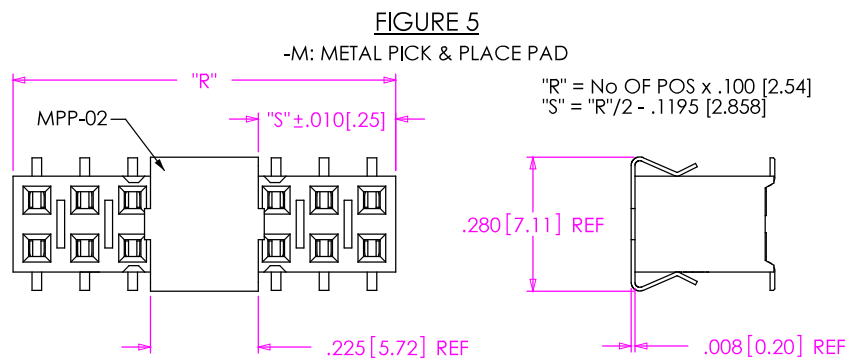
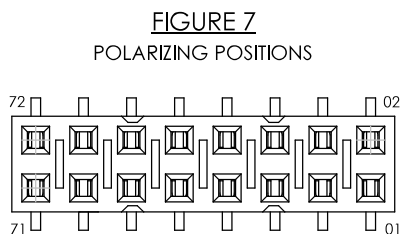
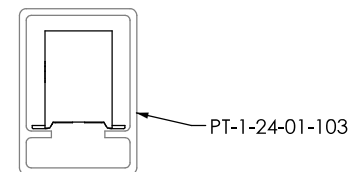
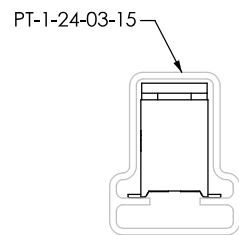

FIGURE 5
-M: METAL PICK & PLACE PAD

TABLE 1

OPTION	PACKAGING TUBE	PLUG	POSITIONS ALLOWED
NONE, -LC, -A, -LC-K	PT-1-24-01-103	TP-09	02 THRU 40
-P-LC	PT-1-24-03-15	TP-03	04 THRU 40
-K, -M	PT-1-24-01-45	TP-09	02 THRU 40



PROPRIETARY NOTE
THIS DOCUMENT CONTAINS INFORMATION CONFIDENTIAL AND PROPRIETARY TO SAMTEC, INC. AND SHALL NOT BE REPRODUCED OR TRANSFERRED TO OTHER DOCUMENTS OR DISCLOSED TO OTHERS OR USED FOR ANY PURPOSE OTHER THAN THAT WHICH IT WAS OBTAINED WITHOUT THE EXPRESSED WRITTEN CONSENT OF SAMTEC, INC.

DO NOT SCALE DRAWING

SHEET SCALE: 2.5:1

SAMTEC

520 PARK EAST BLVD, NEW ALBANY, IN 47150
 * PHONE: 812.944.6733 * FAX: 812.948.5047
 e-Mail: INFO@SAMTEC.COM CODE: 55322

DESCRIPTION:
 .100 C.L. DOUBLE VERTICAL SMT SOCKET STRIP

DWG. NO.
SSM-1XX-XXX-DV-XX-XX-X-XX

BY: KEVIN B 3/8/2000 SHEET 2 OF 2